

### SECTION 3. EDDY CURRENT INSPECTION

#### 5-25. EDDY CURRENT INSPECTION.

Eddy current is used to detect surface cracks, pits, subsurface cracks, corrosion on inner surfaces, and to determine alloy and heat-treat condition.

**a. Eddy Current Instruments.** A wide variety of eddy current test instruments are available. The eddy current test instrument performs three basic functions: generating, receiving, and displaying. The generating portion of the unit provides an alternating current to the test coil. The receiving section processes the signal from the test coil to the required form and amplitude for display. Instrument outputs or displays consist of a variety of visual, audible, storage, or transfer techniques utilizing meters, video displays, chart recorders, alarms, magnetic tape, computers, and electrical or electronic relays.

**b. Principles of Operations.** Eddy currents are induced in a test article when an alternating current is applied to a test coil (probe). The alternating current in the coil induces an alternating magnetic field in the article which causes eddy currents to flow in the article. (See figure 5-3.)

(1) Flaws in or thickness changes of the test-piece influence the flow of eddy currents and change the impedance of the coil accordingly. (See figure 5-4.) Instruments display the impedance changes either by impedance plane plots or by needle deflection.

(2) Figure 5-5 shows typical impedance plane display and meter display instrument responses for aluminum surface cracks, subsurface cracks, and thickness.

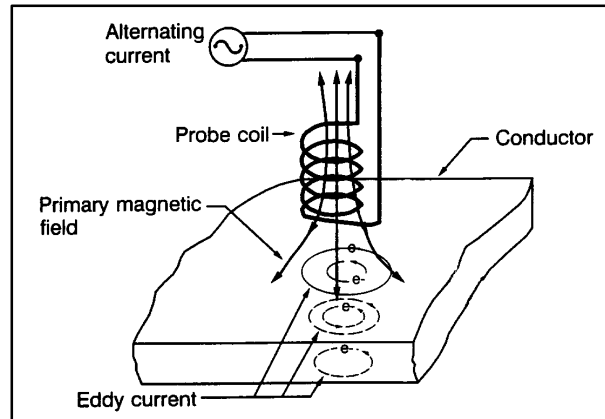

FIGURE 5-3. Generating an eddy current.

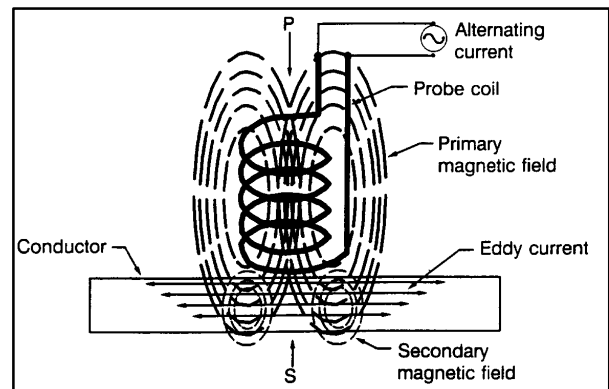

FIGURE 5-4. Detecting an eddy current.

#### 5-26. EDDY CURRENT COILS AND PROBES.

A wide variety of eddy current coils and probes is available. Coils and probes are not always interchangeable between various types of instruments and, for best results, should be matched to a specific instrument and frequency range. Special probe holders can be fabricated to facilitate eddy current inspection of contoured or shaped parts including part edges.

#### 5-27. FIELD APPLICATION OF EDDY CURRENT INSPECTION.

Eddy current techniques are particularly well-suited for detection of service-induced cracks in the field.

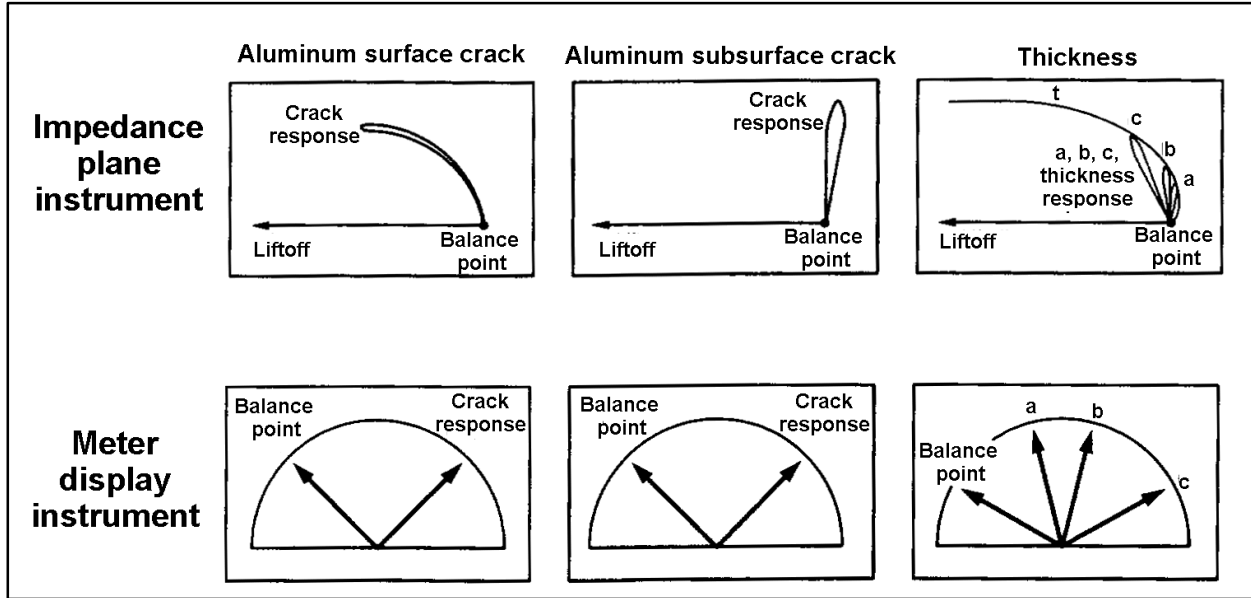

FIGURE 5-5. Typical instrument displays.

Service-induced cracks in aircraft structures are generally caused by fatigue or stress corrosion. Both types of cracks initiate at the surface of a part. If this surface is accessible, a high-frequency eddy current inspection can be performed with a minimum of part preparation and a high degree of sensitivity. If the surface is less accessible, such as in a subsurface layer of structure, low-frequency eddy current inspection can usually be performed. Eddy current inspection can usually be performed without removing surface coatings such as primer, paint, and anodic films. Eddy current inspection has the greatest application for inspecting small localized areas where possible crack initiation is suspected rather than for scanning broad areas for randomly-oriented cracks. However, in some instances it is more economical to scan relatively large areas with eddy current rather than strip surface coatings, inspect by other methods, and then refinish.

**5-28. SURFACE INSPECTION.** Eddy current inspection techniques are used to inspect for surface cracks such as those shown in figure 5-6.

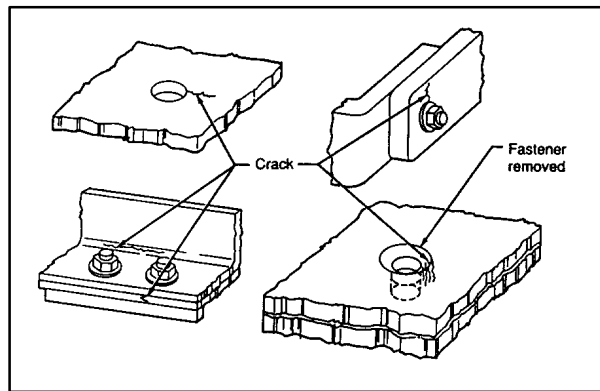

FIGURE 5-6. Typical surface cracks.

**a. Equipment Requirements.** The following are typical eddy current equipment requirements for surface crack inspections.

(1) Instruments must meet the lift-off and sensitivity requirements of the applicable NDI procedures. The frequency requirement is generally 100 Hz to 200 kHz.

(2) Many types of probes are available such as: flat-surface; spring-loaded; pencil; shielded pencil; right-angle pencil; or fastener hole probes.

(3) A reference standard is required for the calibration of Eddy Current test equipment. A reference standard is made from the same material as that which is to be tested. A reference standard contains known flaws or cracks and could include items such as: a flat surface notch, a fastener head, a fastener hole, or a countersink hole.

#### 5-29. SUBSURFACE INSPECTION.

Eddy current inspection techniques are used to inspect for subsurface cracks such as those shown in figure 5-7. The following are typical eddy current equipment requirements for subsurface crack inspections.

a. **Use a variable frequency instrument** with frequency capability from 100 Hz to 500 MHz.

b. **The probe used** would be a low-frequency; spot, ring, or sliding probe.

c. **Use a reference standard** appropriate for the inspection being performed.

#### 5-30. CORROSION INSPECTION.

Eddy current inspection is used to detect the loss of metal as a result of corrosion. An estimation of material loss due to corrosion can be made by comparison with thickness standards. Figure 5-8 shows typical structural corrosion that may be detected by the use of eddy current inspection. Remove all surface corrosion

before performing the eddy current corrosion inspection. The following are typical eddy current equipment requirements for corrosion inspection.

a. **Use a variable frequency instrument** with frequency capability from 100 Hz to 40 kHz.

b. **Use a shielded probe** with coil diameter between 0.15 and 0.5 inch and designed to operate at the lower frequencies.

c. **A reference standard** made from the same alloy, heat treatment, and thickness as the test structure will be required.

#### 5-31. ESTABLISHING EDDY CURRENT INSPECTION PROCEDURES.

When establishing eddy current inspection procedures, where no written procedures are available, the following factors must be considered: type of material to be inspected; accessibility of the inspection area; material or part geometry, the signal-to-noise ratio, test system; lift-off effects, location and size of flaws to be detected; scanning pattern; scanning speed; and reference standards. All of these factors are interrelated. Therefore, a change in one of the factors may require changes in other factors to maintain the same level of sensitivity and reliability of the eddy current inspection procedure. Written procedures should elaborate on these factors and place them in their proper order.

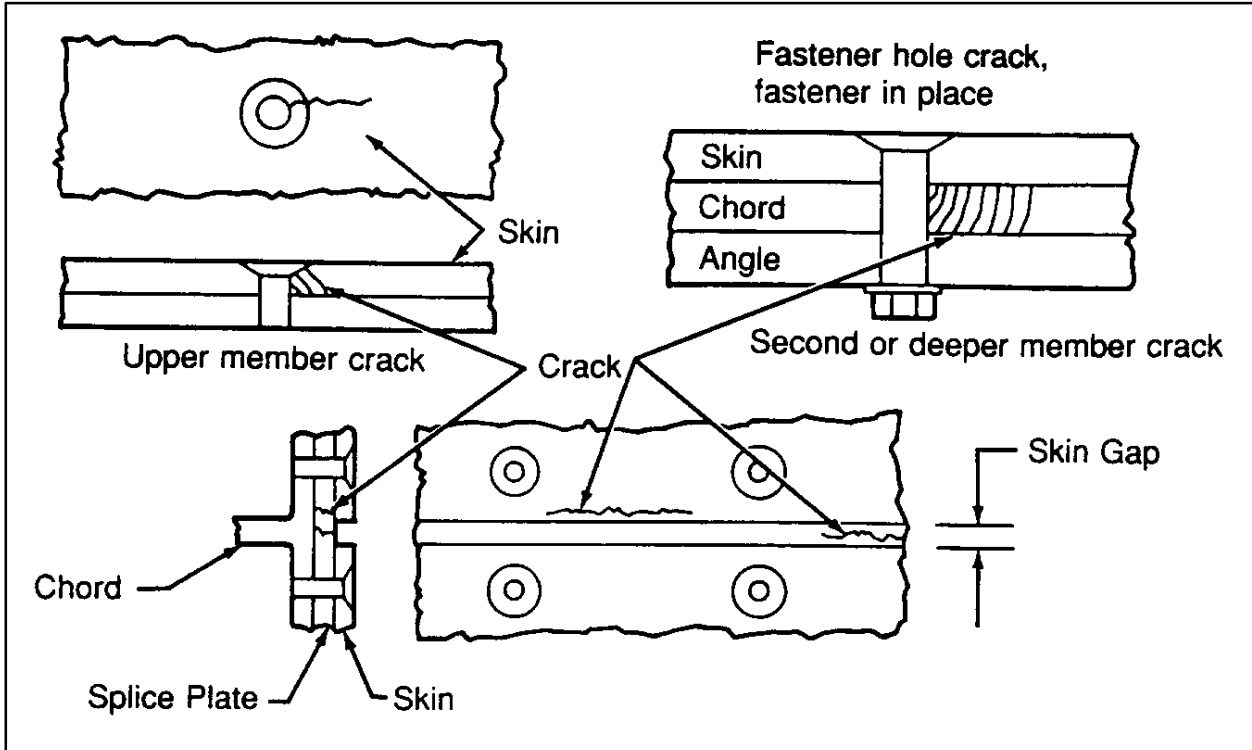

FIGURE 5-7. Typical subsurface cracks.

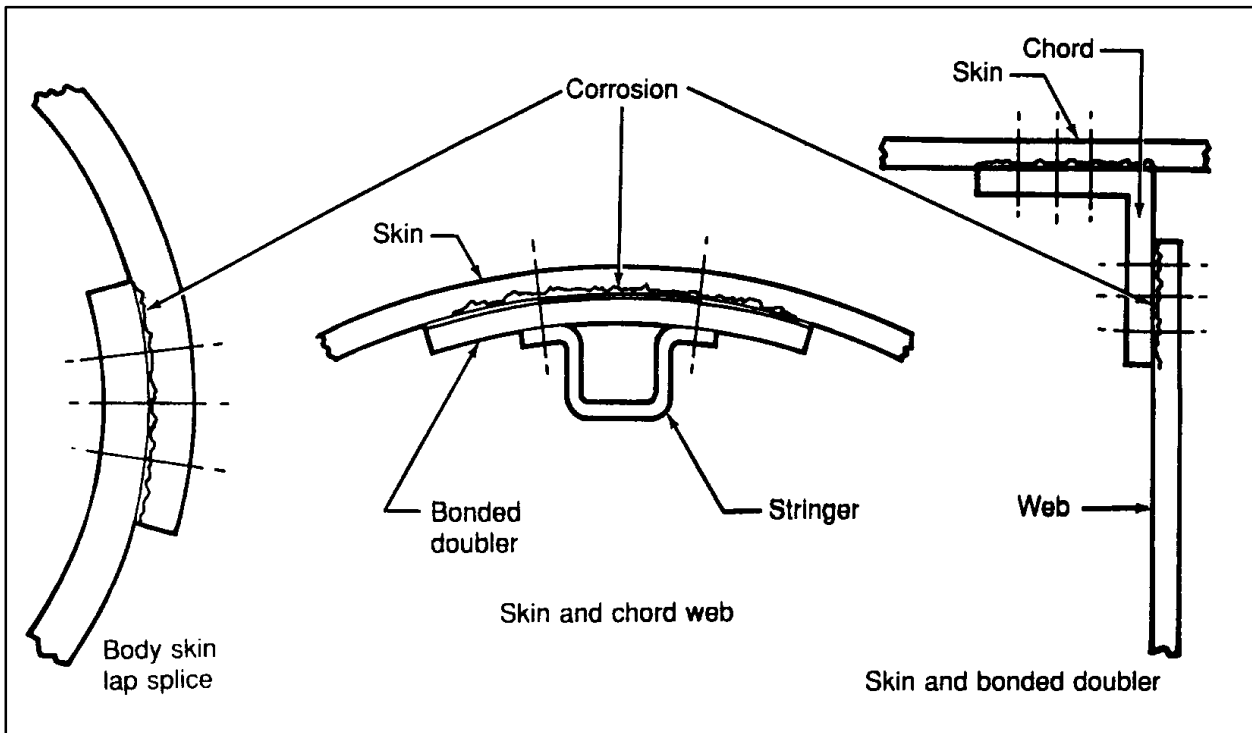

FIGURE 5-8. Typical structural corrosion.

5-32.—5-39. [RESERVED.]